

Kress

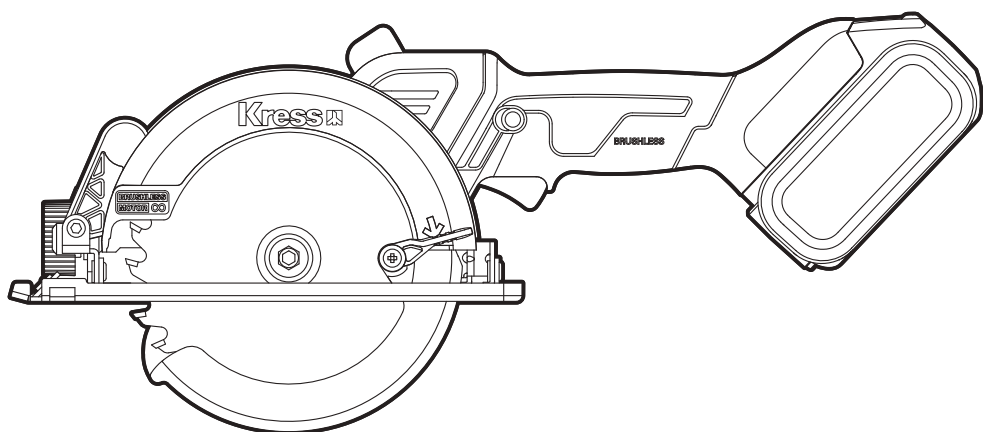

SAFETY AND OPERATING MANUAL

**Lithium-Ion brushless circular saw
KUE11 KUE11.9**



PRODUCT SAFETY

GENERAL SAFETY

WARNINGS

 **WARNING** Read all safety warnings, instructions, illustrations and specifications provided with this power tool. Failure to follow all instructions listed below may result in electric shock, fire and/or serious injury. Save all warnings and instructions for future reference.

The term "power tool" in the warnings refers to your mains-operated (corded) power tool or battery-operated (cordless) power tool.

1) Work area safety

- a) **Keep work area clean and well lit.** Cluttered or dark areas invite accidents.
- b) **Do not operate power tools in explosive atmospheres, such as in the presence of flammable liquids, gases or dust.** Power tools create sparks which may ignite the dust or fumes.
- c) **Keep children and bystanders away while operating a power tool.** Distractions can cause you to lose control.

2) Electrical safety

- a) **Power tool plugs must match the outlet. Never modify the plug in any way. Do not use any adapter plugs with earthed (grounded) power tools.** Unmodified plugs and matching outlets will reduce risk of electric shock.
- b) **Avoid body contact with earthed or grounded surfaces, such as pipes, radiators, ranges and refrigerators.** There is an increased risk of electric shock if your body is earthed or grounded.
- c) **Do not expose power tools to rain or wet conditions.** Water entering a power tool will increase the risk of electric shock.
- d) **Do not abuse the cord. Never use the cord for carrying, pulling or unplugging the power tool. Keep cord away from heat, oil, sharp edges or moving parts.** Damaged or entangled cords increase the risk of electric shock.
- e) **When operating a power tool outdoors, use an extension cord suitable for outdoor use.** Use of a cord suitable for outdoor use reduces the risk of electric shock.
- f) **If operating a power tool in a damp location is unavoidable, use a residual current device (RCD) protected supply.** Use of an RCD reduces the risk of electric shock.

3) Personal safety

- a) **Stay alert, watch what you are doing and use common sense when operating a power tool. Do not use a power tool while you are tired or under the influence of**

drugs, alcohol or medication. A moment of inattention while operating power tools may result in serious personal injury.

- b) **Use personal protective equipment. Always wear eye protection.** Protective equipment such as dust mask, non-skid safety shoes, hard hat, or hearing protection used for appropriate conditions will reduce personal injuries.
 - c) **Prevent unintentional starting. Ensure the switch is in the off-position before connecting to power source and/or battery pack, picking up or carrying the tool.** Carrying power tools with your finger on the switch or energising power tools that have the switch on invites accidents.
 - d) **Remove any adjusting key or wrench before turning the power tool on.** A wrench or a key left attached to a rotating part of the power tool may result in personal injury.
 - e) **Do not overreach. Keep proper footing and balance at all times.** This enables better control of the power tool in unexpected situations.
 - f) **Dress properly. Do not wear loose clothing or jewellery. Keep your hair and clothing away from moving parts.** Loose clothes, jewellery or long hair can be caught in moving parts.
 - g) **If devices are provided for the connection of dust extraction and collection facilities, ensure these are connected and properly used.** Use of dust collection can reduce dust-related hazards.
 - h) **Do not let familiarity gained from frequent use of tools allow you to become complacent and ignore tool safety principles.** A careless action can cause severe injury within a fraction of a second.
- 4) **Power tool use and care**
 - a) **Do not force the power tool. Use the correct power tool for your application.** The correct power tool will do the job better and safer at the rate for which it was designed.
 - b) **Do not use the power tool if the switch does not turn it on and off.** Any power tool that cannot be controlled with the switch is dangerous and must be repaired.
 - c) **Disconnect the plug from the power source and/or remove the battery pack, if detachable, from the power tool before making any adjustments, changing accessories, or storing power tools.** Such preventive safety measures reduce the risk of starting the power tool accidentally.
 - d) **Store idle power tools out of the reach of children and do not allow persons unfamiliar with the power tool or these instructions to operate the power tool.** Power tools are dangerous in the hands of untrained users.

- e) **Maintain power tools and accessories.** Check for misalignment or binding of moving parts, breakage of parts and any other condition that may affect the power tool's operation. If damaged, have the power tool repaired before use. Many accidents are caused by poorly maintained power tools.
- f) **Keep cutting tools sharp and clean.** Properly maintained cutting tools with sharp cutting edges are less likely to bind and are easier to control.
- g) **Use the power tool, accessories and tool bits etc. in accordance with these instructions, taking into account the working conditions and the work to be performed.** Use of the power tool for operations different from those intended could result in a hazardous situation.
- h) **Keep handles and grasping surfaces dry, clean and free from oil and grease.** Slippery handles and grasping surfaces do not allow for safe handling and control of the tool in unexpected situations.
- 5) **Battery tool use and care**
- a) **Recharge only with the charger specified by the manufacturer.** A charger that is suitable for one type of battery pack may create a risk of fire when used with another battery pack.
- b) **Use power tools only with specifically designated battery packs.** Use of any other battery packs may create a risk of injury and fire.
- c) **When battery pack is not in use, keep it away from other metal objects, like paper clips, coins, keys, nails, screws or other small metal objects, that can make a connection from one terminal to another.** Shorting the battery terminals together may cause burns or a fire.
- d) **Under abusive conditions, liquid may be ejected from the battery; avoid contact. If contact accidentally occurs, flush with water. If liquid contacts eyes, additionally seek medical help.** Liquid ejected from the battery may cause irritation or burns.
- e) **Do not use a battery pack or tool that is damaged or modified.** Damaged or modified batteries may exhibit unpredictable behaviour resulting in fire, explosion or risk of injury.
- f) **Do not expose a battery pack or tool to fire or excessive temperature.** Exposure to fire or temperature above 130 °C may cause explosion.
- g) **Follow all charging instructions and do not charge the battery pack or tool outside the temperature range specified in the instructions.** Charging improperly or at temperatures outside the specified range may damage the battery and increase the risk of fire.
- 6) **Service**
- a) **Have your power tool serviced by a qualified repair person using only identical replacement parts.** This will ensure that the safety of the power tool is maintained.

- b) **Never service damaged battery packs.** Service of battery packs should only be performed by the manufacturer or authorized service providers.

SAFETY INSTRUCTIONS FOR ALL SAWS

CUTTING PROCEDURES

- a)  **DANGER: Keep hands away from cutting area and the blade.** If both hands are holding the saw, they cannot be cut by the blade.
- b) **Do not reach underneath the workpiece.** The guard cannot protect you from the blade below the workpiece.
- c) **Adjust the cutting depth to the thickness of the workpiece.** Less than a full tooth of the blade teeth should be visible below the workpiece.
- d) **Never hold the workpiece in your hands or across your leg while cutting. Secure the workpiece to a stable platform.** It is important to support the work properly to minimise body exposure, blade binding, or loss of control.
- e) **Hold the power tool by insulated gripping surfaces, when performing an operation where the cutting tool may contact hidden wiring.** Contact with a "live" wire will also make exposed metal parts of the power tool "live" and could give the operator an electric shock.
- f) **When ripping, always use a rip fence or straight edge guide.** This improves the accuracy of cut and reduces the chance of blade binding.
- g) **Always use blades with correct size and shape (diamond versus round) of arbour holes.** Blades that do not match the mounting hardware of the saw will run off-centre, causing loss of control.
- h) **Never use damaged or incorrect blade washers or bolt.** The blade washers and bolt were specially designed for your saw, for optimum performance and safety of operation.

FURTHER SAFETY INSTRUCTIONS FOR ALL SAWS

Kickback causes and related warnings

- kickback is a sudden reaction to a pinched, jammed or misaligned saw blade, causing an uncontrolled saw to lift up and out of the workpiece toward the operator;
- when the blade is pinched or jammed tightly by the kerf closing down, the blade stalls and the motor reaction drives the unit rapidly back toward the operator;
- if the blade becomes twisted or misaligned in the cut, the teeth at the back edge of the blade can dig into the top surface of the wood causing the blade to climb out of the kerf and jump back toward the operator.
- Kickback is the result of saw misuse and/or incorrect operating procedures or conditions and can be avoided by taking proper precautions as given below.

**Lithium-Ion brushless circular saw
KUE11 KUE11.9**

- a) **Maintain a firm grip on the saw and position your arms to resist kickback forces. Position your body to either side of the blade, but not in line with the blade.** Kickback could cause the saw to jump backwards, but kickback forces can be controlled by the operator, if proper precautions are taken.
 - b) **When blade is binding, or when interrupting a cut for any reason, release the trigger and hold the saw motionless in the material until the blade comes to a complete stop. Never attempt to remove the saw from the work or pull the saw backward while the blade is in motion or kickback may occur.** Investigate and take corrective actions to eliminate the cause of blade binding.
 - c) **When restarting a saw in the workpiece, centre the saw blade in the kerf so that the saw teeth are not engaged into the material.** If a saw blade binds, it may walk up or kickback from the workpiece as the saw is restarted.
 - d) **Support large panels to minimise the risk of blade pinching and kickback.** Large panels tend to sag under their own weight. Supports must be placed under the panel on both sides, near the line of cut and near the edge of the panel.
 - e) **Do not use dull or damaged blades.** Unsharpened or improperly set blades produce narrow kerf causing excessive friction, blade binding and kickback.
 - f) **Blade depth and bevel adjusting locking levers must be tight and secure before making the cut.** If blade adjustment shifts while cutting, it may cause binding and kickback.
 - g) **Use extra caution when sawing into existing walls or other blind areas.** The protruding blade may cut objects that can cause kickback.
- c) **The lower guard may be retracted manually only for special cuts such as “plunge cuts” and “compound cuts.”** Raise the lower guard by retracting handle and as soon as the blade enters the material, the lower guard must be released. For all other sawing, the lower guard should operate automatically.
 - d) **Always observe that the lower guard is covering the blade before placing the saw down on bench or floor.** An unprotected, coasting blade will cause the saw to walk backwards, cutting whatever is in its path. Be aware of the time it takes for the blade to stop after switch is released.

ADDITIONAL SAFETY RULES FOR YOUR CIRCULAR SAW

1. Use only saw blades recommended by the manufacturer, which conform to EN 847-1, if intended for wood and analogous materials.
2. Do not use any abrasive wheels.
3. Use only blade diameter(s) in accordance with the markings.
4. Identify the correct saw blade to be used for the material to be cut.
5. Use only saw blades that are marked with a speed equal or higher than the speed marked on the tool.

ADDITIONAL SAFETY RULES:

1. **Always wear a dust mask.**

SAFETY INSTRUCTIONS FOR CIRCULAR SAW WITH INNER PENDULUM GUARD

Lower guard function

- a) **Check the lower guard for proper closing before each use. Do not operate the saw if the lower guard does not move freely and close instantly. Never clamp or tie the lower guard into the open position.** If the saw is accidentally dropped, the lower guard may be bent. Raise the lower guard with the retracting handle and make sure it moves freely and does not touch the blade or any other part, in all angles and depths of cut.
- b) **Check the operation of the lower guard spring. If the guard and the spring are not operating properly, they must be serviced before use.** Lower guard may operate sluggishly due to damaged parts, gummy deposits, or a build-up of debris.











SAFETY WARNINGS FOR BATTERY PACK

- a) **Do not dismantle, open or shred cells or battery pack.**
- b) **Do not short-circuit a battery pack. Do not store battery packs haphazardly in a box or drawer where they may short-circuit each other or be short-circuited by conductive materials.** When battery pack is not in use, keep it away from other metal objects, like paper clips, coins, keys, nails, screws or other small metal objects, that can make a connection from one terminal to another. Shorting the battery terminals together may cause burns or a fire.
- c) **Do not expose battery pack to heat or fire. Avoid storage in direct sunlight.**
- d) **Do not subject battery pack to mechanical shock.**
- e) **In the event of battery leaking, do not allow the liquid to come into contact with the skin or eyes. If contact has been made,**







**Lithium-Ion brushless circular saw
KUE11 KUE11.9**

wash the affected area with copious amounts of water and seek medical advice.

- f) **Keep battery pack clean and dry.**
- g) **Wipe the battery pack terminals with a clean dry cloth if they become dirty.**
- h) **Battery pack needs to be charged before use. Always refer to this instruction and use the correct charging procedure.**
- i) **Do not maintain battery pack on charge when not in use.**
- j) **After extended periods of storage, it may be necessary to charge and discharge the battery pack several times to obtain maximum performance.**
- k) **Recharge only with the charger specified by Kress. Do not use any charger other than that specifically provided for use with the equipment.**
- l) **Do not use any battery pack which is not designed for use with the equipment.**
- m) **Keep battery pack out of the reach of children.**
- n) **Retain the original product literature for future reference.**
- o) **Remove the battery from the equipment when not in use.**
- p) **Dispose of properly.**
- q) **Do not mix cells of different manufacture, capacity, size or type within a device.**
- r) **Keep the battery away from microwaves and high pressure.**

	Make sure the battery is removed prior to changing accessories.
	Wear protective gloves
	Li-Ion battery This product has been marked with a symbol relating to 'separate collection' for all battery packs and battery pack. It will then be recycled or dismantled in order to reduce the impact on the environment. Battery packs can be hazardous for the environment and for human health since they contain hazardous substances.
	TCT blade
	Wood
	Incorrect
	Correct
	Lock
	Unlock
	The box is recyclable at the kerbside.
	RCM marking

SYMBOLS

	To reduce the risk of injury, user must read instruction manual
	Warning
	Wear ear protection
	Wear eye protection
	Wear dust mask
	Batteries may enter water cycle if disposed improperly, which can be hazardous for ecosystem. Do not dispose of waste batteries as unsorted municipal waste.
	Do not burn

ABN: Australian Business Number. By this number, business information such as entity type, status, business location etc. can be found at website <http://abr.business.gov.au>. ABN of Positec Australia Pty Limited is 14 101 682 357

Lithium-Ion brushless circular saw KUE11 KUE11.9

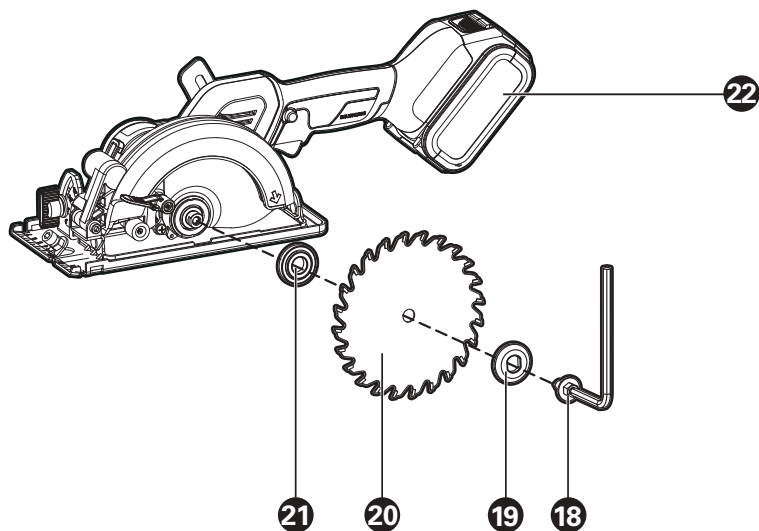
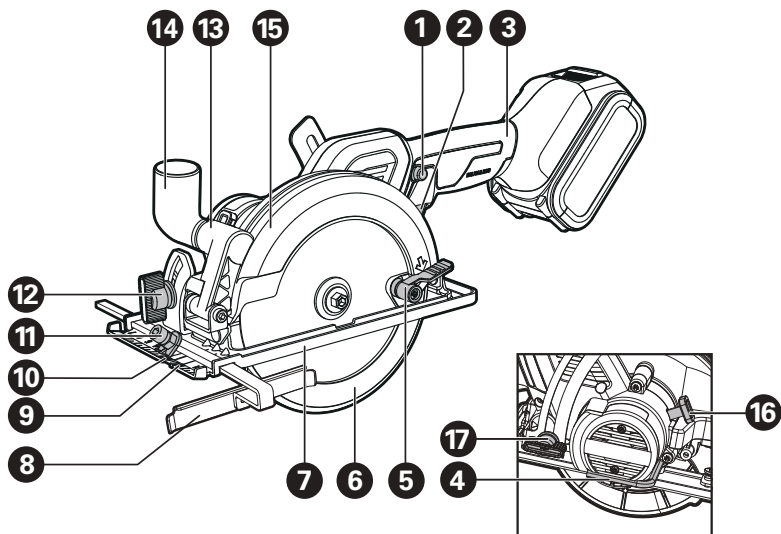

Lithium-Ion brushless circular saw KUE11 KUE11.9

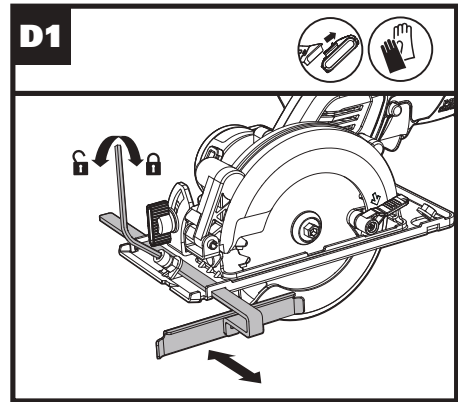
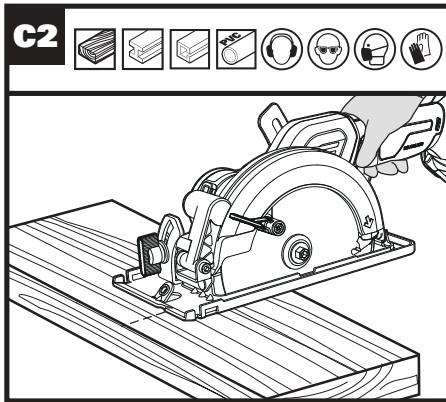
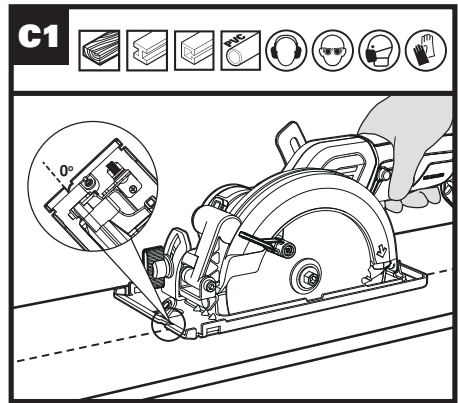
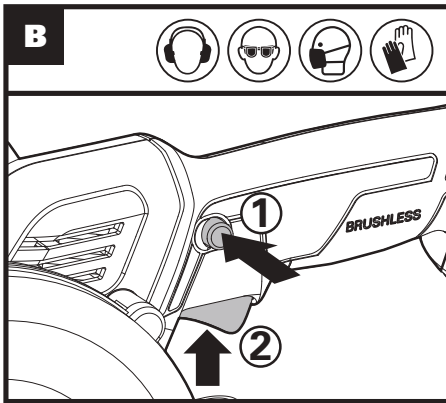
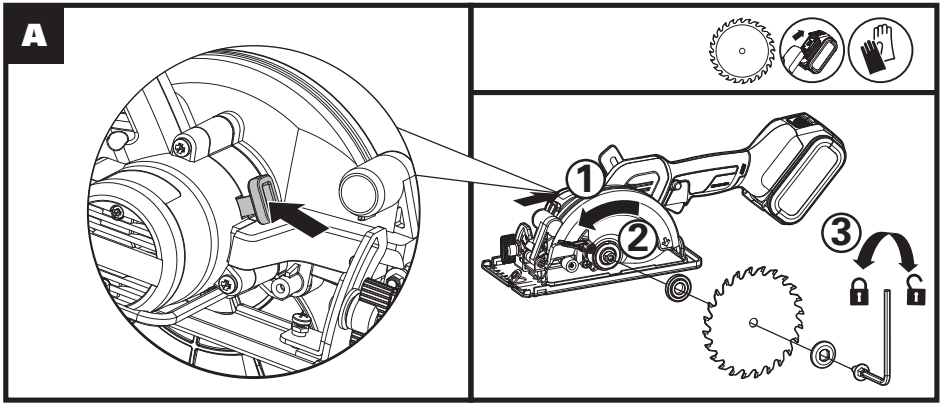

**Lithium-Ion brushless circular saw
KUE11 KUE11.9**

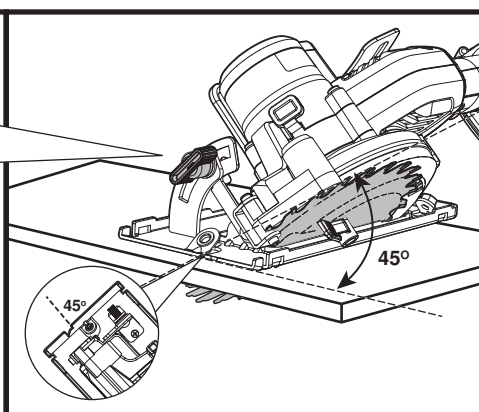
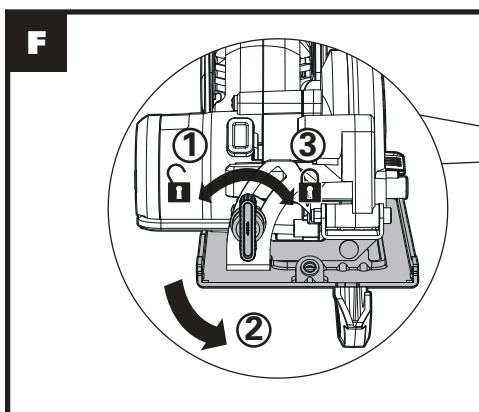
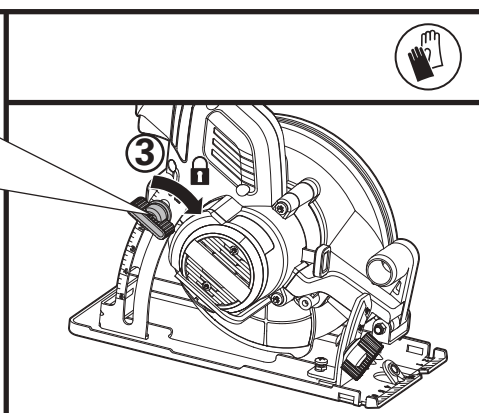
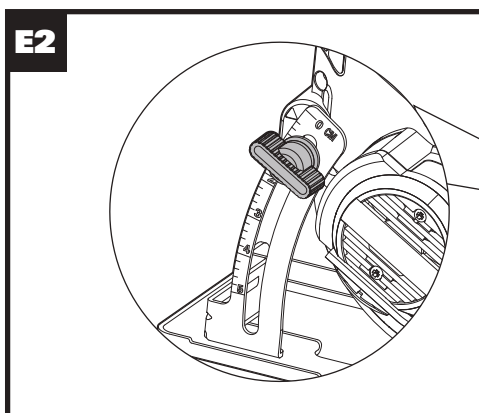
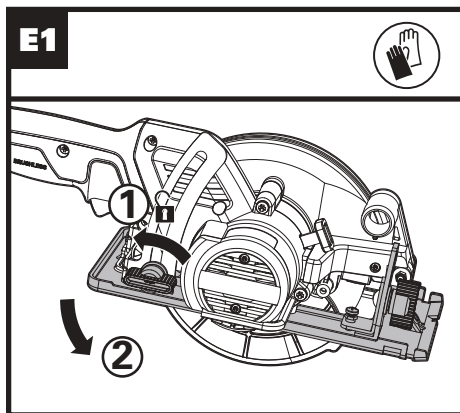
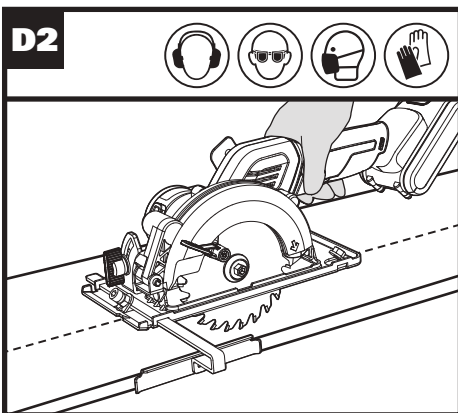

**Lithium-Ion brushless circular saw
KUE11 KUE11.9**

G1

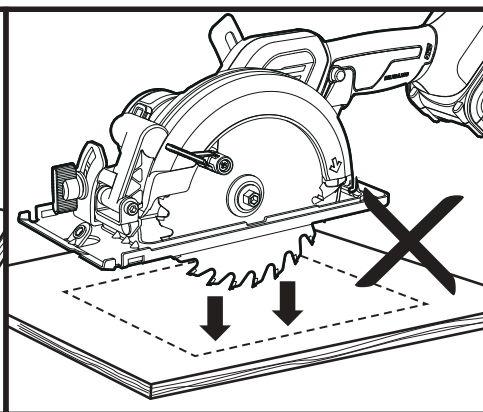
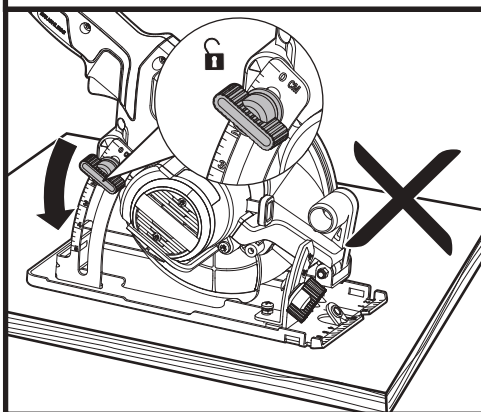
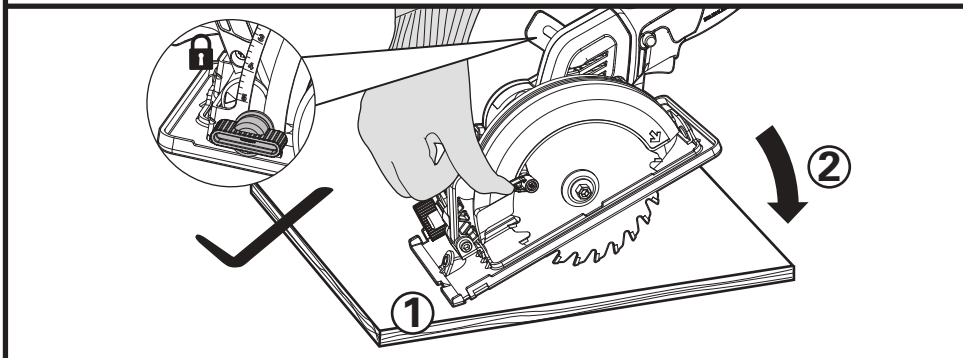

10

G2

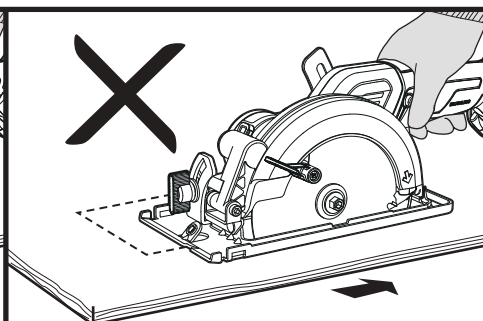
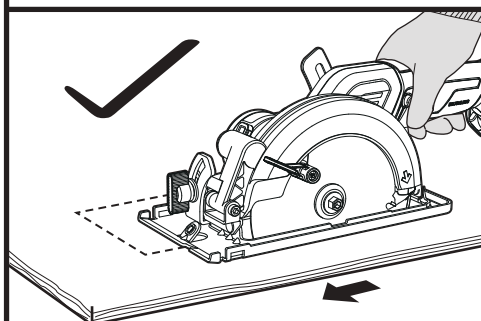

Lithium-Ion brushless circular saw KUE11 KUE11.9

H

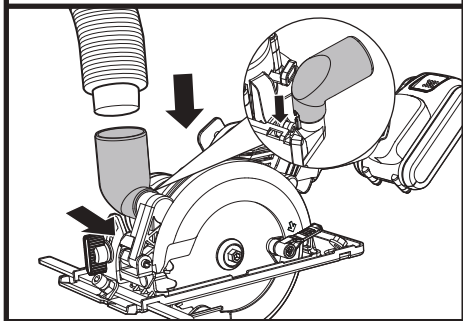

COMPONENT LIST

1.	SAFETY SWITCH
2.	ON/OFF TRIGGER
3.	SOFT GRIP HANDLE
4.	HEX KEY
5.	BLADE GUARD LEVER
6.	BLADE GUARD
7.	BASE PLATE
8.	PARALLEL GUIDE
9.	CUTTING MARK, 0°
10.	CUTTING MARK, 45°
11.	PARALLEL GUIDE CLAMPING FIXTURE
12.	BEVEL ADJUSTMENT LEVER
13.	DUST EXTRACTION OUTLET
14.	VACUUM ADAPTER
15.	FIXED UPPER BLADE GUARD
16.	SPINDLE LOCK BUTTON
17.	DEPTH ADJUSTMENT LEVER
18.	BLADE BOLT
19.	OUTER FLANGE
20.	SAW BLADE*
21.	INNER FLANGE
22.	BATTERY PACK*

*Not all the accessories illustrated or described are included in standard delivery.

TECHNICAL DATA

Type **KUE11 KUE11.9 (E11- designation of machinery, representative of Saw)**

	KUE11 KUE11.9	
Voltage	20V $\overline{\text{=}}$ Max**	
No load speed	6900/min	
Blade size	140mm	
Cutting capacity	Cutting Depth at 90°	51mm
	Cutting Depth at 45°	35mm
Bevel capacity	0-45°	
Machine weight (Bare tool)	1.8kg	

**Voltage measured without workload. Initial battery voltage reaches maximum of 20 volts. Nominal voltage is 18 volts.

ACCESSORIES

	KUE11	KUE11.9
140mm saw blade	1	1
Battery pack	2(KAB21)	/
Charger	1(KAC21)	/
Parallel Guide	1	1
Vacuum Adaptor	1	1
Strap	1	1

We recommend that you purchase your accessories from the same store that sold you the tool. Refer to the accessory packaging for further details. Store personnel can assist you and offer advice.

OPERATING INSTRUCTIONS



NOTE: Before using the tool, read the instruction book carefully.

WARNING: Do not release the handle until the saw blade come to complete stop and do not touch saw blade while the saw blade is running.

Intended use: The tool is intended for ripping and cross-cutting wood and other materials in straight cutting lines, while resting firmly on the work piece.

ASSEMBLY AND OPERATION

ACTION	FIGURE
ASSEMBLY	
Mounting and Removing the Blade NOTE: Lock or loose the blade bolt, the spindle lock button should be pressed.	See Fig. A
WARNING: Always remove the battery before changing the blade!	
Safety switch and On/Off trigger WARNING: To avoid cutting injury from the sharp blade, please don't put your hands around the Base Plate. NOTE: Keep the dust adapter connected to dust collecting device when using the tool.	See Fig. B

Lithium-Ion brushless circular saw KUE11 KUE11.9

Rip and Cross Cutting NOTE: The cutting line of saw blade is aligned with the cutting mark 0°.	See Fig. C1, C2
Parallel Guide	See Fig. D1, D2
Adjusting the Cutting Depth	See Fig. E1, E2
Adjusting the Cutting Angle NOTE: The cutting line of saw blade is aligned with the cutting mark 45°.	See Fig. F
Pocket /Plunge	See Fig. G1, G2
Sawdust Removal	See Fig. H

FOR BATTERY TOOLS

The ambient temperature range for the use and storage of tool and battery is 0°C-45°C.

The recommended ambient temperature range for the charging system during charging is 0°C-40°C.

WORKING HINTS FOR YOUR TOOL

If your power tool becomes too hot, please run your circular saw no load for 2-3 minutes to cool the motor. Avoid prolonged usage at very low speeds.

Protect saw blades against impact and shock. Cutting with extreme force can significantly reduce the performance capability of the tool and reduce the service life of the saw blade. Sawing performance and cutting quality depend essentially on the condition and the tooth count of the saw blade. Therefore, use only sharp saw blades that are suited for the material being cut.

Choice of blades: 24 teeth for general work, approx. 40 teeth for finer cuts, more than 40 teeth for very fine cuts into delicate surfaces, diamond for tile, cement board, etc.

Only use saw blades recommended.

MAINTAIN TOOLS WITH CARE

Remove the battery before carrying out any adjustment, servicing or maintenance.

Keep tools sharp and clean for better and safer performance. Follow instructions for lubricating and changing accessories. Inspect tool cords periodically and if damaged, have repaired by authorized service facility. Your power tool requires no additional lubrication or maintenance. There are no user serviceable parts in your power tool. Never use water or chemical cleaners to clean your power tool. Wipe clean with a dry cloth. Always store your power tool in a dry place. Keep the motor ventilation slots clean. Keep all working controls free of dust.

Periodically clear dust and chips from guard and base to ensure proper performance.

TROUBLE SHOOTING

Symptom	Possible Causes	Possible Solution
Tool will not start when operating the on/off trigger.	Battery pack not plugged in. Battery pack powered off.	Check to make sure battery pack is connected well into a working outlet. Charging the battery.
Cutting depth is less than that is set.	Sawdust accumulated at the rear of the base.	Shake out sawdust. Consider connecting a vacuum for dust collection.
Blade spins or slips	Blade is not tightly engaged with the spindle.	Remove the blade and reassemble it as described in Mounting and Removing the Blade section.
Blade will not cut a straight line.	Blade is dull. Blade is not mounted properly. Saw is not being guided properly.	Mount a new, sharp blade on the saw. Check that blade is properly mounted. Use a parallel guide.
Blade kicks back when beginning a cut	Saw blade teeth may be engaged in the material when starting. Blade is not spinning fast enough	Before restarting a saw in the workpiece, center the saw blade in the kerf and check that the saw teeth are not engaged into the material. Allow the saw blade to reach full speed prior to beginning a cut in the material.

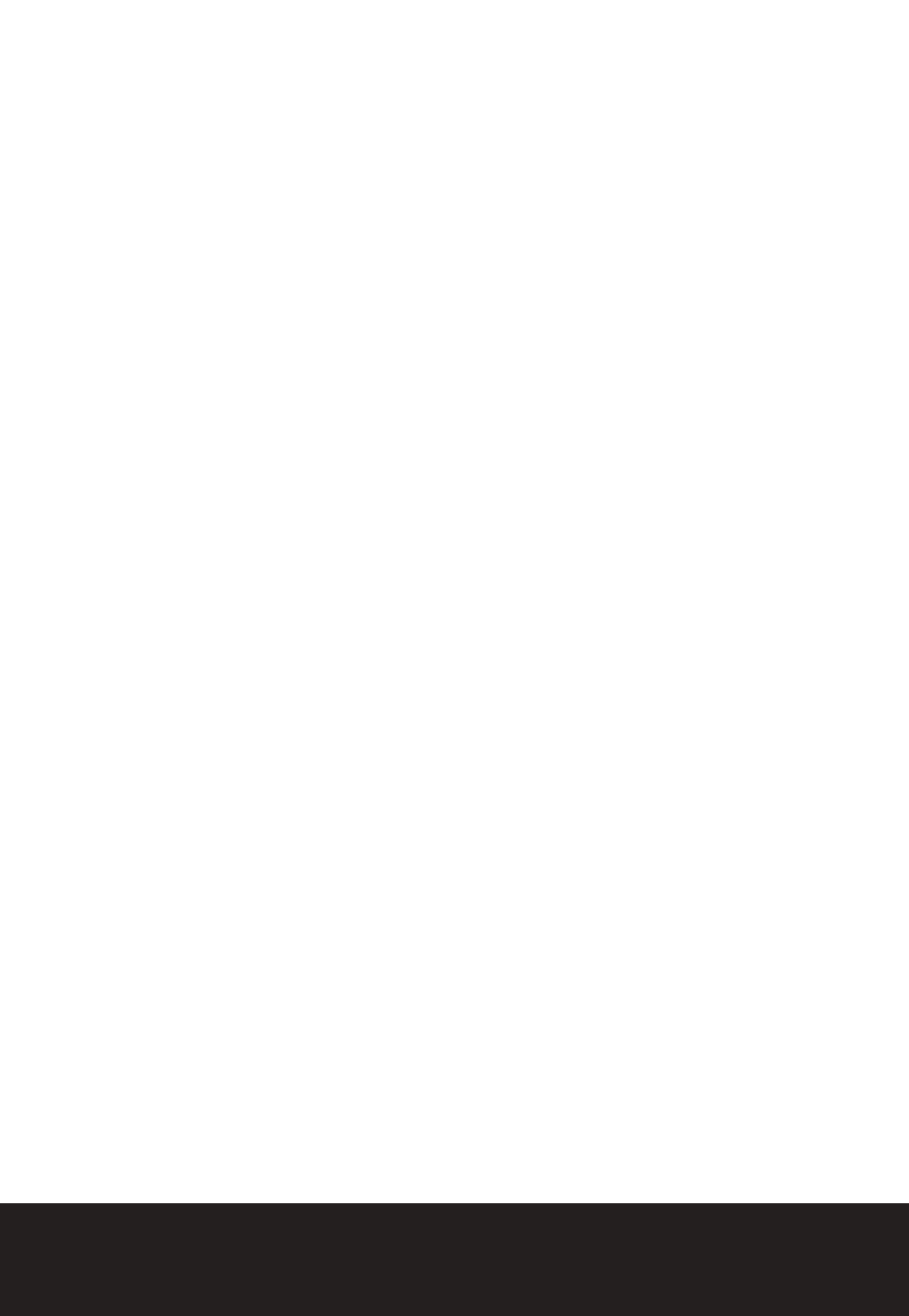

Kress 